

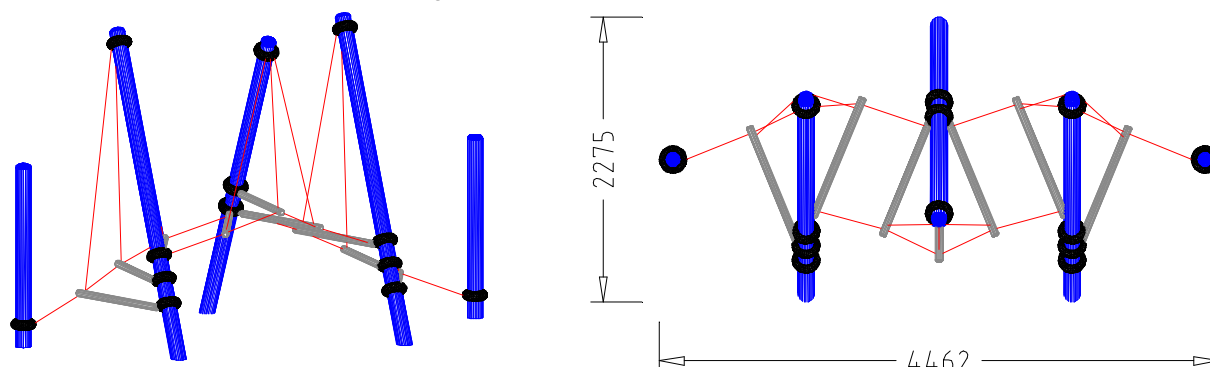

Product Specification

Product Family	: TerranosNetscapes
Product name	: Sculptura.02
Item number	: 95.180.020
Children's age	: 5 +
Fall Height (EN1176)	: 1.24 m (4'-1")
Dimensions: Length, width, height	: 4.5 x 2.3 x 2.8 m (14'-8" x 7'-6" x 8'-11")
Protective Surfacing Area required (EN1176)	: 7.5 x 5.3 m
Protective Surfacing Area required (ASTM 1487)	: 6.0 x 8.2 m (19'-6" x 26'-8")
Minimum space required	: EN1176: 30.0 m ² / ASTM 1487: 36.2 m ²
Number of foundations	: 5
Concrete Volume C20/25 (3.000 psi)	: 2.6 m ³
Number of skilled installers required	: 2
Installation time without foundations	: 2 hours
Dimensions of largest part	: 0.14 x 0.54 x 4.10 m (5½" x 1'-9" x 13'-6")
Weight of heaviest part	: 95 kg
Freight volume	: 4.0 m ³
Gross weight	: 550 kg
Spare part guarantee	: Lifelong

Certificate according to EN 1176 No.: Z2 05 10 10256 037 – TÜV Product Service



Product description: (also available as a doc. file upon request).

The Netscape from the modular **netplay system Terranos** includes the following elements:

Steel posts Jan:	Steel pipes \varnothing 133 mm (5 ¼") with a rounded cast aluminum post top, minimum wall thickness 7.1mm (1/4"); anticorrosion treatment and color finish: sandblasting and zinc-/ epoxy-/ polyester-process.
Terranos clamps:	Two-part cast aluminum connecting clamps for the height-adjustable connection of rope elements or steel pipes to Terranos steel posts.
Rope:	U-Rope -round strand ropes with galvanized steel cores, \varnothing 16mm (5/8") – unless otherwise noted; external strands are covered with non-abrasive UV-resistant Polyamide-yarn (no Polypropylene!).
Floating bridge elements:	Stainless steel pipe railings, \varnothing 60.3 mm (2 3/8"); anticorrosion treatment and color finish: sandblasting and zinc-/ epoxy-/ polyester-process.